

Trouble-Shooting Flooding of Paper Dryers

Gregory L. Wedel
President
Kadant Johnson Inc.

Ken Hill
President, Systems Division
Kadant Johnson Inc.

Technical White Paper Series

EXECUTIVE SUMMARY

A paper dryer is heated by condensing steam inside the dryer cylinder. The condensate must be removed from the dryer at the same rate at which it is being formed or the dryer will “flood”. That is, condensate will accumulate inside the dryer. An excessive amount of condensate in the dryer will increase the power required to drive the dryer and reduce the rate of heat transfer from the dryer. This paper covers some of the main causes for dryer flooding.

CONTENTS

Introduction	3
Condensate Behavior	3
Flooding Description	5
Drying Drainage	6
Troubleshooting Dryer Flooding	10
Mechanical Problems	10
Steam System Problems	13
Conclusions	16
References	16

INTRODUCTION

Paper dryers can experience periodic problems with flooding. A “flooded” dryer is one that has an excessive amount of condensate in it. The condensate may be either in a non-rimming condition (in which case the drive load can be high) or in a rimming condition (in which case the heat transfer rate will be low).

In normal operation, the rate at which condensate is being evacuated from a dryer matches the rate at which condensate is forming in the dryer. “Flooding” occurs when condensate is being evacuated from the dryer at a rate that is less than the rate at which steam is condensing in the dryer. A dryer begins to recover from a flooded condition when the evacuation rate exceeds the condensing rate.

A brief outline of some of the causes of dryer flooding is given in the sections below. These sections should help in trouble-shooting problems with flooded dryers.

CONDENSATE BEHAVIOR

In a conventional paper dryer, pressurized steam is supplied to the dryer through a rotary joint. The steam transfers its heat to the inside surface of the dryer shell and the shell in turn transfers the heat to the paper that is passing over its outer surface. The steam condenses as it loses its heat to the dryer shell and the condensed steam (called “condensate”) is removed from the dryer by a syphon. A typical paper dryer is shown in cross-section in the figure below.

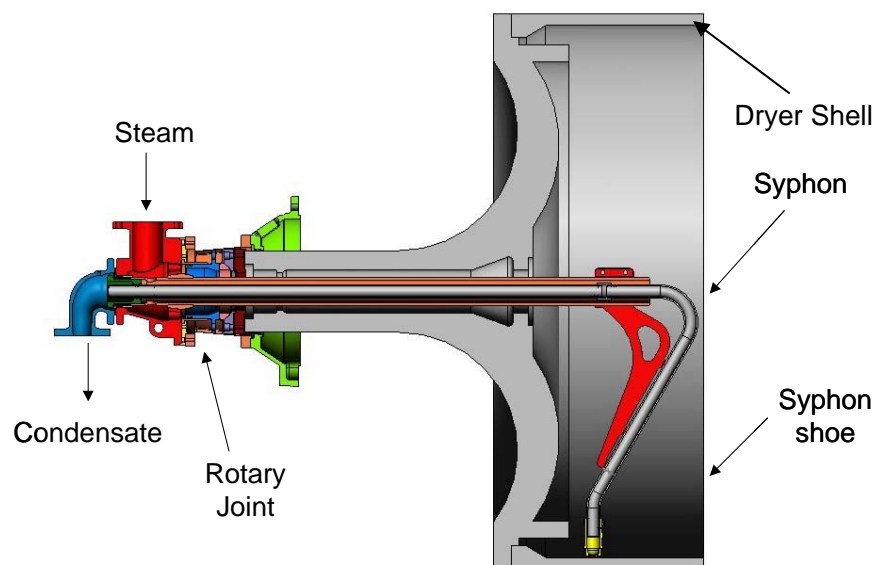

The condensate that remains in a dryer cylinder may be in any one of three states of behavior. These states depend primarily on the rotational speed of the dryer cylinder and the amount of condensate in the dryer. At slow speeds, typically less than 300 fpm (about 100 mpm), the condensate will form a puddle at the bottom of the dryer cylinder. In this state, the power required to rotate the dryer is relatively low. As the dryer rotational speed increases, the puddle moves in the direction of rotation and widens in the direction of rotation. The drive power remains low, as long as the puddle remains near the bottom of the dryer. This state is called the “puddling” or “ponding” state.

As the dryer speed increases, the trailing edge of the condensate puddle starts to extend over the horizontal centerline of the dryer cylinder and the condensate falls (“cascades”) back to the bottom of the dryer. The height to which the condensate rises before it cascades increases with the dryer speed, as does the amount of the condensate that is cascading. The combination of the increasing elevation and increasing condensate volume causes a quadratic increase in the power required to rotate the dryer as speed increases. This second condensate state is called “cascading”.

The third state occurs as speed is increased further and the condensate forms a rimming layer all around the inside surface of the dryer shell. The drive power in this state is much lower than in the cascading state.

These three states of condensate behavior are shown in the figure below.

Dryers can flood with the condensate in any one of these three states.

Once the condensate is in the rimming state, it will tend to stay in the rimming state unless the amount of condensate increases or the dryer speed decreases. If the dryer speed is decreased, the rimming condensate layer will eventually collapse and the condensate will return to a cascading state and eventually back to a puddling state. There is a distinct hysteresis effect: The dryer speed at which the condensate layer collapses is less than the speed at which the rimming layer was first established.

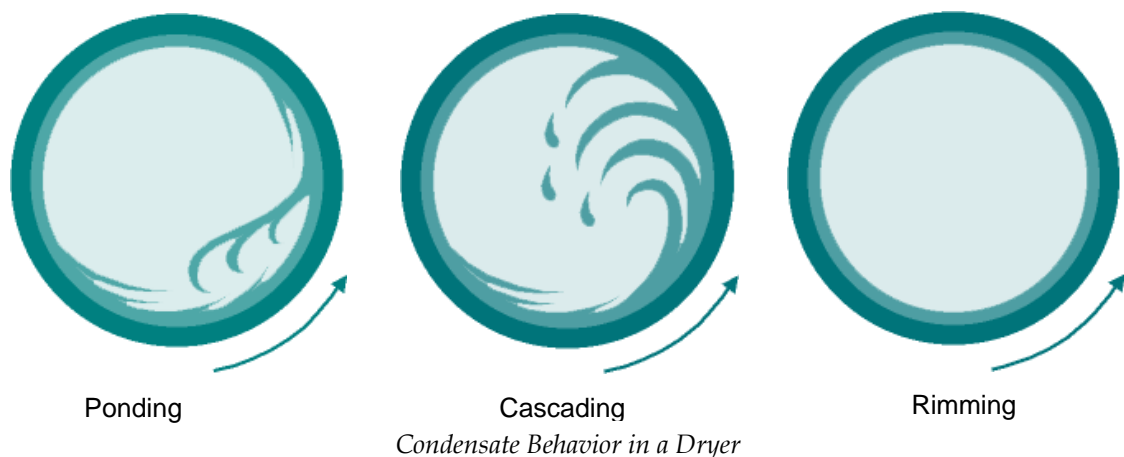

FLOODING DESCRIPTION

As noted above, a “flooded” dryer is one that has an excessive amount of condensate in it. “Excessive” is a relative term and it can sometimes be difficult to know whether or not a dryer is in the process of flooding, or is in the process of recovering from a flooded condition.

Generally, a flooded dryer is identified by one or more of the following symptoms:

- *The dryer drive loads are much higher than normal for the current operating speed.*
- *The dryer framework is swaying in the cross-machine direction (dryers may sometimes sway in the machine-direction as well, but dryer framing is normally much stiffer in the machine-direction).*
- *Operating dryer steam pressures have increased or the dryer section is unable to maintain the target sheet moisture content (the drying rate has decreased).*
- *Condensate is leaking out of the steam seal in the rotary steam joint or manhole cover opening.*
- *The flow rate of condensate (observed in the sight flow glass) has decreased or stopped.*
- *A felt-driven dryer is rotating at a speed that is lower than the rest of the dryers (the dryer is slipping in the dryer fabric).*
- *The dryer surface temperature (measured with a contacting pyrometer) is lower than normal for the machine operating at that dryer steam pressure and dryer speed.*
- *The dryer head temperature (measured with an infrared gun) is lower than normal for the machine operating at that dryer steam pressure and dryer speed.*

The following definitions may be helpful when reviewing indications of dryer flooding:

Flooded:	An excessive amount of condensate is already in the dryer.
Flooding:	The amount of condensate in the dryer is increasing above normal.
Recovering:	The rate at which the condensate is being evacuated from the dryer is greater than the rate at which condensate is forming inside a flooded dryer.
Recovered:	The amount of condensate inside the dryer has returned to normal.

DRYER DRAINAGE

Condensate is evacuated (“drained”) from a dryer cylinder through a syphon pipe. The syphon pipe extends from the inside surface of the dryer shell, out through the hollow dryer journal, and into the rotary steam joint. A syphon “shoe” (or “hopper” or “syphon tip”) is typically attached to the end of the syphon pipe that is adjacent to the inside surface of the dryer shell.

The type of syphon and its design can have a very significant effect on the removal of condensate from the dryers and can be a critical factor in the performance of high-speed dryers, especially their tendency toward flooding.

There are two primary types of dryer syphons: Rotating syphons and stationary syphons. A rotating syphon is simply one that rotates with the dryer shell. A rotating syphon shoe is held in direct contact with the inside surface of the dryer shell, sometimes with bolts and sometimes with a spring force. Modern rotating syphon shoes have close-fitting clearance to the dryer shell (typically 0.06 – 0.10”) and large perimeters (15-20”) in order to minimize the amount of rimming condensate that remains in the dryers. Rotating syphons are designed to produce thin condensate layers so that the heat transfer rate and heat transfer uniformity are kept at acceptable levels. Kadant Johnson pioneered the development of rotating syphon shoes specifically for high-speed dryers. These syphon shoes have a unique contour so they can also effectively evacuate non-rimming condensate. A typical rotating syphon is shown in the figure below. This rotating syphon is spring-loaded against the dryer shell so that no bolt holes are required in the dryer shell to hold the syphon in place.

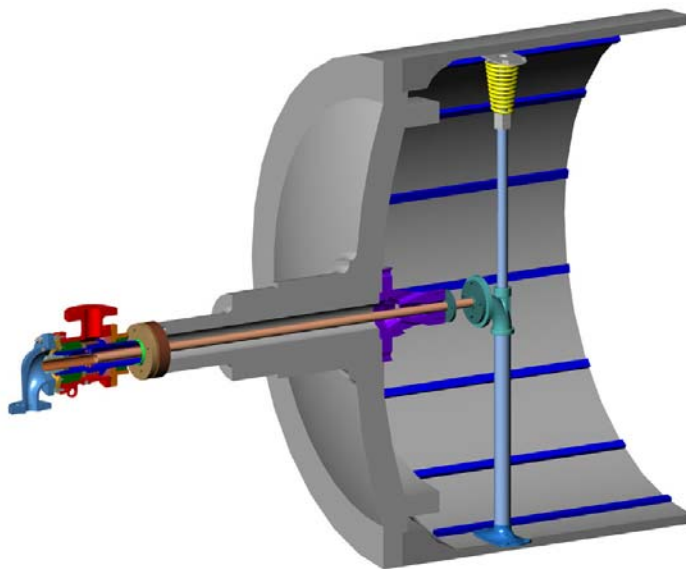

With both rotating and stationary syphons, the condensate inside the dryer must be lifted up the syphon pipe in order to evacuate it from the dryer. Differential steam pressure is used to lift the condensate up the radial syphon pipe. With a rotating syphon, there is a centrifugal force that tends to hold the condensate against the dryer shell. At high dryer speeds, this centrifugal force can be quite large (55 times the force of gravity when a 5' diameter dryer is running at 4,000 fpm). The corresponding differential pressure required to lift the condensate against this centrifugal force can also be quite large. If the syphon must lift a solid column of condensate to the center of the dryer under these operating conditions, the differential pressure would theoretically have to be 28 psi!

In practice, the operating differential pressures are generally less than this theoretical value because uncondensed steam ("blow through" steam) is evacuated along with the condensate and this blow through steam greatly reduces the effective density of the mixture and thereby greatly reduces the required differential pressure.

If, however, the tip of the rotating syphon becomes submerged in condensate, then only condensate will flow into the syphon pipe and the differential pressure will have to be high enough to lift the heavy condensate.

If the differential pressure is high, but not quite high enough to lift the condensate all the way to the center of the dryer, then the condensate will not flow out of the dryer. This is like sucking water out of a glass with a straw, but not having enough vacuum to lift the water all the way to your mouth. The phenomenon is shown schematically in the figure below.

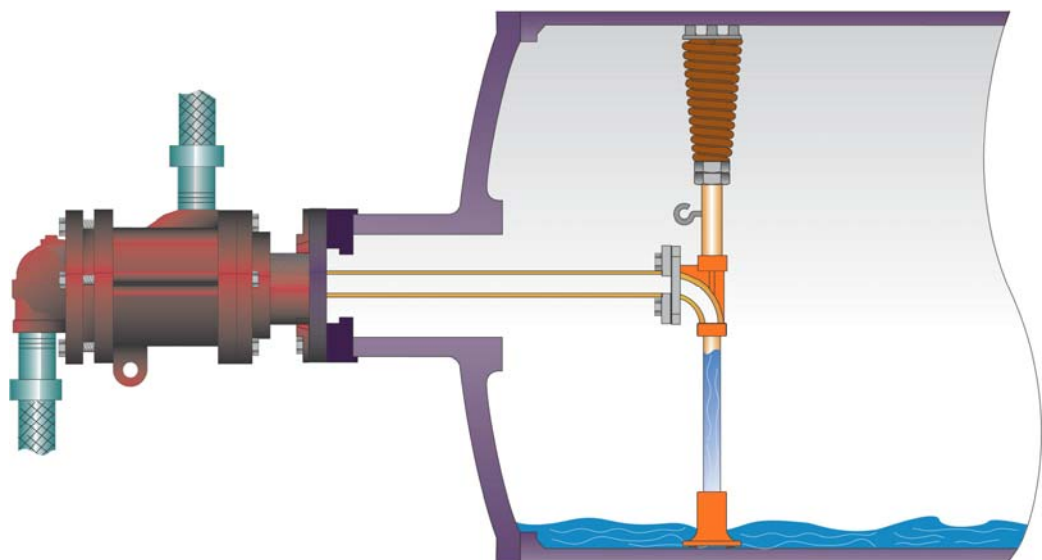

Note that in the above figure, the syphon shoe is entirely submerged in condensate, so only condensate enters the syphon pipe. The differential pressure lifts this condensate up the syphon pipe, against the centrifugal force, but only to a height that corresponds to the differential pressure. In this figure, the differential pressure was not high enough to evacuate the condensate and the dryer would eventually flood.

The minimum differential pressure required to lift a solid column of condensate up a rotating syphon pipe to the dryer axis depends primarily on the dryer speed and, to a much lesser degree on the steam pressure (condensate density) and dryer diameter. This minimum “flood recovery” differential pressure is shown as function of dryer speed in the following graph:

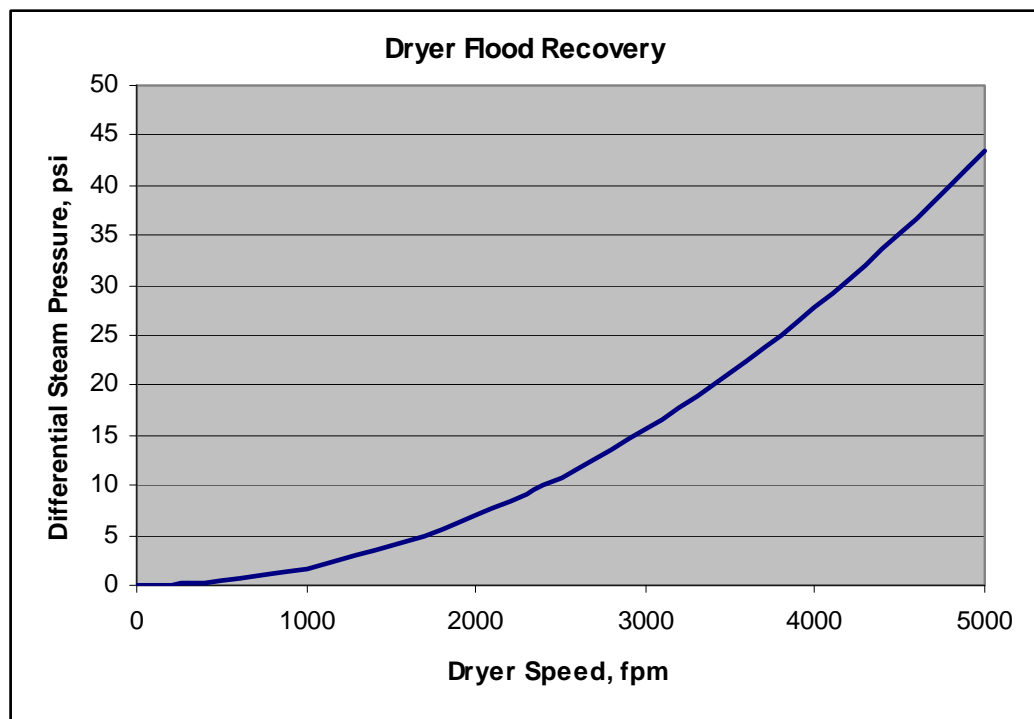

The minimum differential pressure required to evacuate a flooded dryer (one with the rotating syphon tip submerged in condensate) can be reduced by adding a small “aspirator” hole in the tip of the syphon shoe, just far enough above the condensate layer so that blow through steam can enter the syphon pipe through the aspirator hole and reduce the density of the fluid in the radial pipe. The amount of reduction depends on the size of the aspirator hole, the speed of the dryer, and the operating steam pressure. For dryers operating at high speed, an aspirator hole that is 0.25” diameter and located in the syphon shoe about 2” above the dryer shell could reduce the minimum differential pressures for flood recovery by about 25% below the values shown in the graph above.

At high speeds, however, even a 25% reduction in flood recover differential pressure still leaves a high differential pressure. During normal operation, when the condensate is being properly evacuated, these high operating differential pressures can result in excessive amounts of blow through steam passing through the dryer. It can be very difficult to design a steam system with sufficient flexibility to handle large blow through flow rates. This is why stationary syphons became more common again, when dryer speeds were going over 3000-3500 fpm.

The second type of dryer syphon is the stationary syphon. The most common type of stationary syphon for high-speed machines is the cantilevered stationary syphon shown in the figure below. Modern cantilever stationary syphons have been designed with very rigid supports so that the stationary syphon can withstand the impact forces of the rimming condensate without vibration and failures.

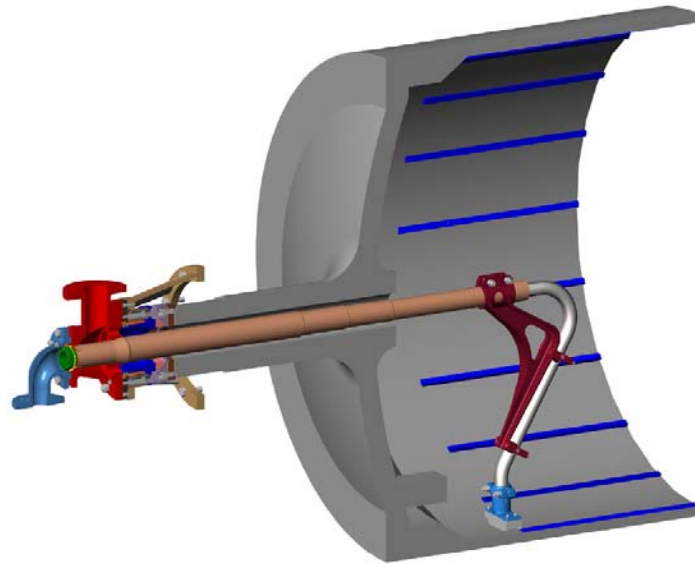

Unlike rotating syphons, a stationary syphon does not have to lift the condensate against centrifugal force. In fact, if the stationary syphon shoe has a "scoop" contour, it is able to use the momentum of the rimming condensate to force the condensate out of the dryer. If the dryer speed is high enough, the condensate may be evacuated from the dryer even if the differential pressure is zero.

The syphon pipe size and operating differential steam pressure can be independently selected when running with a stationary syphon. This allows the equipment supplier to greatly reduce the amount of blow through steam and greatly simplifies the design and stability of the steam and condensate system. The stationary syphons also greatly reduce the susceptibility of paper dryers to flooding.

Although dryers with stationary syphons are much less prone to flooding, flooding can still occur in dryers with stationary syphons, as outlined in the trouble-shooting sections below.

TROUBLESHOOTING DRYER FLOODING

Most problems with dryer flooding are related to either the steam supply and condensate drainage control systems or with mechanical / installation problems. These problems are outlined separately in the sections below.

MECHANICAL PROBLEMS

1. Syphon shoe design. Some older design syphon shoes did not have a “scoop” contour. These syphon shoes can be more susceptible to dryer flooding and often require higher operating differential pressures. Many rotating syphon shoes that do not have a scoop feature will have very poor slow-speed (non-rimming) performance. Many stationary syphon shoes that do not have a scoop feature will have very poor high-speed (rimming) performance.
2. Stationary syphon shoe installed backwards. Scoop-style stationary syphons must face opposite the running direction of the dryer. If they are installed incorrectly, they will be very inefficient in removing condensate and will require high differential steam pressures.
3. Eroded syphon shoe. Syphon shoes can erode over time. If the tip of the shoe is eroded away, the shoe becomes ineffective in removing condensate and dryer flooding results. Gray iron syphon shoes are particularly prone to erosion.
4. Loss of syphon shoe clearance. If the opening under the tip of a rotating syphon is closed off, the dryer will not drain. The clearance can be closed off if the shoe becomes embedded in the shell or if the rotary syphon spacers were not installed.
5. Internal joint leakage. Some styles of dual-flow steam joints can have leakage inside the joint – between the steam supply chamber and the condensate discharge chamber. This can cause dryer flooding, even though there is a sufficient differential pressure across the joint and the amount of blow through is high. This problem can only occur in dual-flow rotary joints, and is much more likely if the dryers have rotating syphons than stationary syphons.

6. Broken syphons. If either the horizontal or vertical syphon pipes break off inside the dryer, the syphon will not drain the condensate. Syphon breakage can be caused by corrosion, loose balance weights, shifting dryer bars, and physical contact between the shell and a stationary syphon.
7. Undersized syphon pipes. The internal syphon piping (vertical and horizontal pipes and shoe) may be too small for the current operating conditions (dryer speed, condensing load, and pressure). If so, higher operating differential pressures will be required, perhaps resulting in inadequate steam system control.
8. Syphon elbow erosion. If the internal dryer syphon elbow is eroded, blow through steam will by-pass the syphon shoe and the dryer will not drain. Cast iron and ductile iron elbows are particularly susceptible to erosion. It may be difficult to detect the erosion during dryer internal inspections. A ball peen hammer can be used to “sound out” the elbows during internal inspection, to identify areas where internal erosion has thinned the wall of the casting.
9. Orifice plate is plugged. Mechanical debris (gaskets, washers, cap screws) that covers a portion of an orifice plate in the condensate drain line will increase the flow resistance and prevent proper condensate drainage from that dryer. If the dryer is equipped with a sight glass, the flooded dryer may be identified by the low flow of condensate.
10. Condensate isolation valve is closed, is not fully open, or does not have a full-bore flow area. Condensate isolation valves should be full-bore valves and must be kept fully open, particularly in dryers with stationary syphons. Normally, the valve position can be indicated by the position of the valve stem or handle, but this is not always the case. The handle or stem may be broken off.
11. Steam supply isolation valve is closed, is not fully open, or does not have a full-bore flow area. Steam supply isolation valves should also be kept fully open, particularly on machines with stationary syphons that are operating with low differential pressures. If the pressure differential is low and the pressure drop across the steam isolation valve is higher on one dryer than the others, then the differential pressure across the dryer cylinder will be disproportionately low and the dryer will not drain properly. If the supply valve flow resistance is too high, the dryer pressure will be less than the condensate header pressure and condensate / steam will flow back into the dryer through the drop leg, as shown in the figure below.

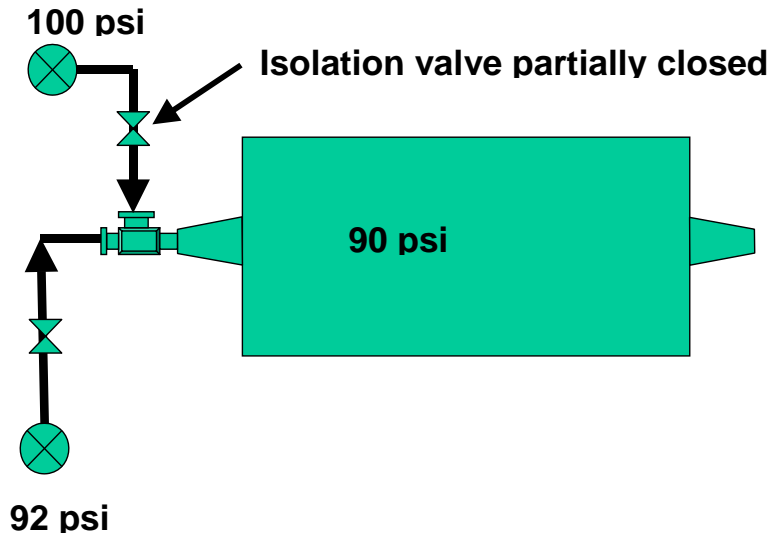

12. Undersized supply and drain pipes. If the drop-legs from the steam supply header and from the dryer cylinders are too small, the differential pressure across the dryer may be inadequate to drain the dryers, even though the differential between the headers is at a reasonable level.
13. Undersized headers. If the steam supply headers and particularly the condensate headers are too small, there will be a large pressure loss along the length of the header. It is not unusual to find a 2 to 3 psi pressure drop in undersized condensate headers. In this case, the dryers at one end of the header will see a different differential pressure than the dryers at the opposite end of the header. Properly sized headers would have less than a 0.5 psi pressure drop.
14. Undersized steam separators. Undersized steam separators can also lead to dryer flooding. Condensate carryover from an undersized separator will add to the condensate load in the dryer. This can be significant, particularly if the tanks are significantly undersized. Properly sized tanks are designed for a 98% quality of blow through steam leaving the tank.
15. Modified piping. The addition of piping tees and elbows to an existing steam system can cause an increase in flow resistance and improper dryer drainage. The changes may not seem to be significant, but changes should be carefully checked.
16. Piping obstructions. Occasionally, debris is left in the dryer piping (pipe plugs, cans, rags, etc). This can greatly reduce the flow capacity and cause dryer flooding.

17. Deposits in Piping. On rare occasions, a black oxide can build up inside paper dryers. These deposits are the result of improper or inadequate treatment of the boiler feed water. The black oxide has been known to plate out on the inside surfaces of the dryer syphon pipes, restricting the flow and increasing the differential pressure.
18. Improperly valved-off dryers. If a dryer is to be valved off to take it out of service, positive shut-off must be maintained for both the steam and condensate lines. This can be done by disconnecting the flex hoses to the joint, putting blank plates between pipe flanges, or having two isolation valves with an open vent line between them, for both the steam and the condensate lines. The latter is referred to as a “double block and bleed” configuration.
19. Plugged process connection lines. Plugged process connection lines will result in inaccurate differential indication. This is a common cause of poor dryer drainage. The process connection lines should be large diameter (Kadant Johnson recommends 2" stainless steel lines). The process connection lines should be vertical with no more than a 45° slope and the lines should be insulated to prevent the formation of condensate in the lines.

STEAM SYSTEM PROBLEMS

1. Low differential pressure. Many steam system problems are related to running the differential pressure too low. This may be the result of setting the DP too low or from controlling to an inaccurate DP signal.

If the normal dryer operating differential pressure is set and controlled to a value that is too low to handle the current operating speed, steam pressure, and condensing load, then the dryer will tend to load up with condensate.

If the set point for the differential pressure is correct, but the differential pressure reading is incorrect, then the operating differential pressure may still be too low. Errors in differential pressure measurement may be caused by either transmitters that are improperly calibrated or by the connecting pressure lines (“impulse lines”) not being properly routed. The latter is covered later in this review.

Note: TAPPI Water Removal Committee has published a Technical Information Paper on recommended operating differential pressures. TIP 0404-31.

The best way to trouble-shoot steam system problems is to directly measure the differential across the dryer (not just between the headers). This requires pressure taps on both the steam supply side and the condensate drainage side of the joint. (Care must be taken to do this work safely).

2. Temporary loss of differential pressure. This problem is most common on high-speed machines operating with rotating syphons. If there is a loss in differential pressure (even a temporary loss), the condensate will cover the clearance between the syphon and the shell. If the differential pressure is restored, but is not above the flood-recovery differential pressure, then the condensate will not be removed from the dryer.

Note: The addition of an aspirator hole in the rotating syphon will significantly improve the flood-recovery performance of the syphon.

Note: It is not uncommon to have a temporary loss in dryer differential pressure during a brief stop or during a sheet break, particularly with older steam and condensate systems.

3. Excessive desuperheater water flow. Water is sprayed into the steam supply piping to reduce the temperature of the steam to a value closer to the saturation steam temperature. If the instrumentation, controls, or water control valves are not properly functioning, an excessive amount of water can be dumped into the steam header. This will greatly increase the amount of water that has to be evacuated from one or more of the dryers in that section.
4. Improper orifice plate size. If the condensate orifice plate is too small, the pressure drop will be higher than expected and the dryer will not drain at the normal operating differential pressure.
5. Incorrect differential pressure indication. This is one of the most common problems. If the indicated differential pressure is higher than the actual differential pressure, the dryers may flood even though the differential pressure appears to be adequate. There are a number of causes of incorrect DP readings:
 - *Transmitter is not functioning*
 - *Transmitter is not properly calibrated*
 - *Water legs on each side of the transmitter are not equal*
 - *Water leg on one side of the transmitter has air in the line.*

- Seal pot is located below one of the headers with poor connection lines.
- Differential pressure is calculated from two pressure readings (double calibration errors and larger range for errors).
- Pressure and DP readings are “calibrated” against inaccurate gauges.

Kadant Johnson has developed guidelines for installing, calibrating, and maintaining differential pressure transmitters. These are available upon request. A typical example of these guidelines is included at the end of this paper.

6. Improper DP valve operation. An inoperative DP valve can cause dryers to flood. If the controls indicate 50% opening, for example, and the DP valve goes to 20% or if it closes when it is supposed to be opening (reversed operation), the dryers will flood.
7. Choked thermocompressor. If the dryer thermocompressor is improperly sized or out of its intended design range, it may be running in “choked flow” condition, where an increase in valve position will result in reduced blow through suction flow rate. If a thermocompressor goes into a choked condition, it is generally because it is oversized. Choking occurs when the nozzle is too large and discharges too much high-pressure steam into the throat of the diffuser thus filling the cross-sectional area and blocking (or choking) the flow of the suction steam. Choking can also occur when the discharge pressure is much less than the original thermocompressor design discharge pressure.
8. Improperly sized thermocompressor. If the thermocompressor is undersized, it will not be able to generate sufficient differential pressure and recirculate the blow through steam.

CONCLUSIONS

There are a number of potential causes of dryer flooding, but most of them can be eliminated by proper hardware selection, system design, and maintenance. The above outline provides a basic guide for troubleshooting dryers that appear to be flooded (high drive loads, swaying dryer frames, and low drying capacity). If the cause cannot be immediately identified, Kadant Johnson can provide an audit of the dryer section to determine the cause. Simulation trials can also be conducted at the Kadant Johnson Research Center in Three Rivers, Michigan if further help is required to identify the conditions under which the dryer floods and the operating parameters required to prevent flooding from occurring.

REFERENCES

1. "Recommended operating differential pressures", TAPPI Technical Information Paper, TIP 0404-31.
2. Wedel, Gregory L., Timm, Gerald L, and Skelton, Mikeal, "Drive Power and Torque in Paper Machine Dryers, 2nd Edition", Kadant Johnson Inc., 2008.
3. Wedel, Gregory L., Timm, Gerald L, Skelton, Mikeal, and Munn, James T, "Drive Power and Torque in Paper Machine Dryers", Kadant Johnson Inc., 2001.
4. Concannon, M.D., "Condensate Effects on Torque and Horsepower in Paper Dryers," Tappi 63(9): 69-72 (1980).
5. White, R.E. and Higgins, T.W., "Effect of the Fluid Properties on Condensate Behavior," Tappi 41 (2): 71-76 (1958).
6. Calkins, D.L., "A Comparison of Rotary & Stationary Siphon Performance in Paper Dryers," Johnson Corporation 1973.
7. Derrick, R. P., "Drive Power Requirements for Pulp and Paper Machine Dryer Sections", 1978 Engineering Conference Proceedings, Book II, Tappi Press, Atlanta, p. 381.
8. Wedel, G. L. and Timm, G. L., "Drive Power and Torque in Paper-machine Dryers", TAPPI Technology Summit 2002, Tappi Press, Atlanta.

Kadant Johnson is a global leader in the design, manufacture, and service of dryer drainage systems, rotary joints, syphon systems, and related equipment for the dryer section of the paper machine. For more information about Kadant Johnson products and services, email info@kadant.com or visit www.kadant.com.

- *Steam and Condensate Systems*
- *Dryer Section Surveys*
- *Dryer Management System® control software*
- *Stationary Syphons*
- *Rotating Syphons*
- *Rotary Joints*
- *Turbulator® Bars*
- *Thermocompressors*
- *Desuperheaters*
- *Direct Injection Water Heaters*
- *Vortec™ Vacuum Generators*
- *Sight Flow Indicators*
- *Flexible Metal Hoses*
- *Installations Services*

KĀDANT
AN ACCENT ON INNOVATION