

Gregory L. Wedel  
President  
Kadant Johnson Inc.

Gerald L. Timm  
Vice President, Research & Development  
Kadant Johnson Inc.

Kenneth C. Hill  
President  
Kadant Johnson Systems Division

Technical White Paper Series

## EXECUTIVE SUMMARY

---

Single-felt dryer sections are used to enhance the runnability of high-speed paper machines. In single-felt dryer sections, the web is supported by the dryer felt (i.e., fabric) in the draws between dryers. Fabric style, air handling equipment, and runnability devices are critical to efficient operation. Steam control in bottom single-felt dryers is also important. This paper covers the main considerations in handling the steam in these dryers and concludes with recommendations concerning steam control and operation of bottom dryers of single-felt dryer sections.

## CONTENTS

---

Introduction .....	3
Dryer Speed in Conventional Dryers Sections .....	3
Dryer Speed in Single-Felt Dyer Sections .....	4
Single-Felt Sheet Speed .....	5
Dryer Drives .....	6
Dryer Surface Temperatures .....	7
Drying Capacity .....	9
Checking Drying Capacity .....	9
Steam Heating Bottom Dryers .....	10
Steam Condensing Load .....	11
Blow-Through Steam .....	12
Steam System Design .....	12
Conclusions .....	14

## INTRODUCTION

---

Many high-speed paper machines have converted conventional two-tier, two-felt dryer sections into single-felt dryer sections (also known as uniron, unorun, single-fabric, and serpentine run dryer sections). In a single-felt dryer section, the single (top) dryer felt follows the sheet path over top dryers and under bottom dryers. This is shown in the figure below.

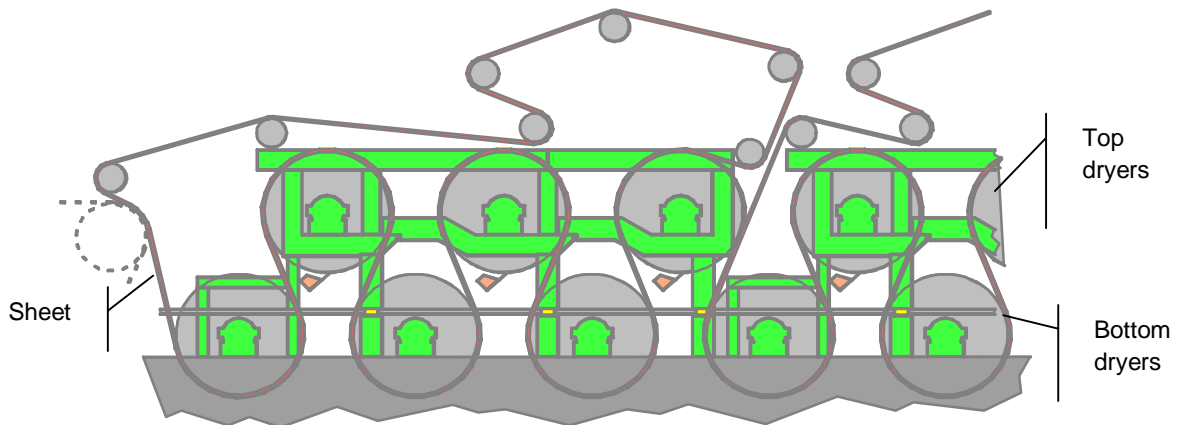

The sheet is held against the surfaces of the top dryers by the felt as it passes over the top dryers and is separated from the surfaces of the bottom dryers as it passes around the bottom dryers on the outside of the felt.

## DRYER SPEED IN CONVENTIONAL DRYER SECTIONS

---

In conventional dryer sections, dryer cylinders are divided into groups of dryers with each of the dryers in a group geared together. When all of the dryers are geared together, all of the cylinders rotate together at the same rotational speed (i.e., revolutions per minute).

Tensioned dryer felts act as drive belts, attempting to keep dryers in their felt loops running at the same surface speed. Dryers that are running at equal rotational speeds will also be running with equal surface speeds, but only if they have exactly the same outside diameters.

In practice, dryer diameters are not exactly the same. New dryers are manufactured with a tolerance on their diameters. Old dryers often have some wear that has reduced their diameters. And, most importantly, identical dryers with different shell temperatures will have different diameters, due to the difference in the amount of thermal expansion. Dryers that are hotter will have larger diameters than dryers that

---

Dryers that are hotter will have larger diameters than dryers that are cooler.

---

are cooler. For example, if top dryers in a conventional two-tier two-felt dryer section are operated with higher steam pressures than bottom dryers, then the top dryers will have larger diameters than the bottom dryers. Similarly, if the top dryer felt has a higher tension, then the heat transfer rate from the steam to the sheet will be higher, the top dryer shell temperatures will be cooler, and the top dryer diameters will be slightly smaller than the bottom dryer diameters.

With separate top and bottom dryer felts, each dryer felt will be running on dryers that have nearly the same temperature as the other dryers in that felt loop. As long as all of the dryers in the felt loop are at the same temperature, those dryers will be running at the same surface speed. But if the dryers in the bottom tier are hotter than the dryers in the top tier, they will be running at a higher surface speed (but the same rotational speed). This can have an adverse effect on sheet runnability in the draws between the top and bottom dryers. The sheet tension will increase in the “down” runs and decrease in the following “up” runs. This can produce tension breaks in the down runs and a slack sheet with subsequent wrinkling in the following up runs.

---

## DRYER SPEED IN SINGLE-FELT DRYER SECTIONS

---

---

If the felt cannot slip on the surface of the dryers, the felt must stretch as it approaches a bottom dryer and contract as it approaches a top dryer.

---

With a single-felted dryer section, the situation is more complicated. As long as the dryers are interconnected with gears, the rotational speed of each dryer remains the same, just as they were in the conventional two-felt dryer section. The bottom dryers may be hotter than the top dryers, as they were in the above example, but now the single felt is running over *both* the top and the bottom dryers. If the felt cannot slip on the surface of the dryers, the felt must stretch as it approaches a bottom dryer and contract as it approaches a top dryer. Correspondingly, the felt tension will increase between a top dryer and the following bottom dryer and decrease between the bottom dryer and the following top dryer. This increase and decrease in felt tension puts additional stress on the dryer gears. This stress can be quite high, particularly for felts that are very stiff.

On some single-felt machines, top dryers are driven by interconnecting gears and bottom dryers are driven by the dryer felt. In these configurations, rotational speeds of cooler top dryers will be higher than the rotational speeds of the hotter bottom dryers, but the felt is not stressed by having dryers with different diameters in the same dryer section. This drive concept is discussed later.

## SINGLE-FELT SHEET SPEED

---

To further complicate the situation, the sheet runs on the *inside* surface of the dryer felt as it goes around the top dryers and it travels on the *outside* surface of the dryer felt as it goes around bottom dryers.

Even if the top and bottom dryers have *exactly* the same diameter, the outer surface of the felt will be running at a higher speed than the inner surface as the felt wraps a dryer, because the felt has a finite thickness. Only the neutral axis (located approximately half-way through the felt thickness) will be running at a constant speed. One surface of the felt expands as it goes over top dryers and contracts as it goes under bottom dryers.

As the sheet passes over the top single-felt dryers, it runs under the dryer felt, in contact with the dryer cylinder. The sheet speed will be essentially the same as the surface speed of the top dryer. This will be less than the speed of the dryer felt neutral axis. As the sheet passes under the bottom single-felt dryers, it runs on the outside of the dryer felt. Since the neutral axis of the dryer felt is running faster than the dryer surface speed, and since the outer surface of the dryer felt is running even faster than its neutral axis, there is a difference in speed between the sheet and the dryer felt surface. Consequently, the sheet must either (1) slip on the dryer felt, (2) stretch and compress as it approaches and leaves the bottom dryer, or (3) some combination of the two.

---

The way the sheet responds depends on the sheet strength, moisture content, surface characteristics, and dryer geometry.

---

The way the sheet responds depends on the sheet strength, moisture content, surface characteristics, and dryer geometry. There are two geometrical relationships that affect the sheet behavior: Speed ratio and length difference.

The difference in speed between the outer surface of the felt on the bottom dryers ( $V_f$ ) and the speed of the top dryer surface ( $V_d$ ) can be calculated by the following equation:

$$S = (V_f - V_d) = (2t / D) V_d$$

where:

S = Speed difference

$V_f$  = Dryer felt outside surface speed

$V_d$  = Dryer outside surface speed

t = Dryer felt caliper

D = Dryer outside diameter

For simplicity, top and bottom dryers are assumed to have equal diameters in the above equation and the neutral axis of the dryer felt is assumed to be half way through the felt thickness. This equation shows that the speed ratio (the effective draw) will be higher for dryer felts

---

If a bottom gear-driven dryer is hotter than the top dryer, then the felt will be stretched more in the down-run from the top dryer and the speed difference will be even larger.

---

that have a large caliper and smaller for dryer sections with large diameter dryers.

If a bottom gear-driven dryer is hotter than the top dryer, then the dryer felt will be stretched more in the down-run from the top dryer and the speed difference will be even larger. Correspondingly, bottom dryer surface temperatures should be maintained at values equal to the top dryer surfaces, particularly in single-felt dryer configurations with interconnecting gears.

The other geometrical relationship is the path length difference. If the sheet strength is high and its elongation is low, it will run at the same speed as the top dryer and slip on the dryer felt rather than stretch and compress as it goes around the bottom dryers. The amount of slippage that occurs as the sheet passes under the dryer (assuming the sheet runs at the dryer surface speed and the dryers have the same diameters) is given by:

$$d = 2 p t (\theta / 360)$$

where:

d = "Scuffing" distance on each bottom dryer

t = Dryer felt caliper

$\theta$  = Wrap angle of felt on dryer, degrees

As long as the dryer diameters are identical, the dryer diameter does not directly affect the scuffing distance, but the amount of scuffing is directly affected by the felt caliper. A thinner felt will produce less scuffing.

## DRYER DRIVES

---

As discussed above, a single-felt dryer section can exert significant stress on dryer gears, if the dryers in the top and bottom tiers are not identical in diameter. Removing bottom dryers from the gear train and using the single felt to drive the bottom dryers can eliminate this problem. This is possible, for example, when the dryer gear train is similar to the one shown in the figure on the following page.

In this dryer drive configuration, the bottom dryers can be disconnected from the gear train by removing the idler gears to the bottom dryers. The top dryers, however, remain in the gear train with their intermediate idler gears in place. "W" style gear trains do not allow this conversion, since each top dryer is driven by the preceding bottom dryer.

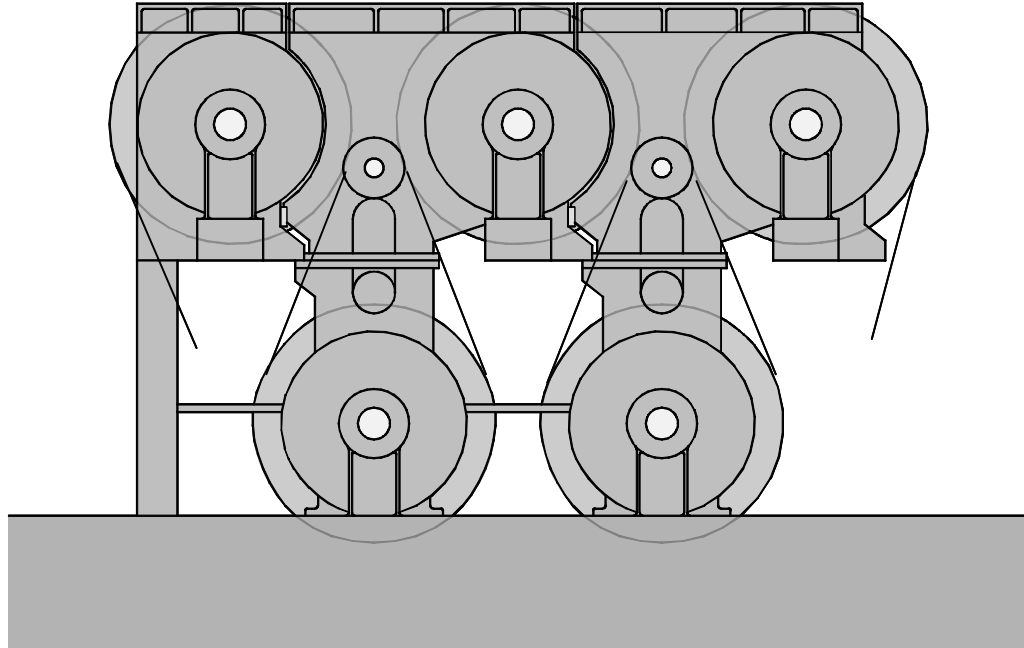

## DRYER SURFACE TEMPERATURES

---

As noted earlier, differences in dryer temperatures can produce differences in dryer diameters. Single-felt dryer sections often have such differences in dryer temperatures.

Single-felt configurations provide higher felt wrap angles on dryers than conventional two-felt dryer section configurations. Higher felt wrap angles tend to increase the amount of heat that is transferred from top dryers to the sheet that is sandwiched between the dryer surface and the dryer felt.

Further, there are no enclosed “pockets” in single-felt dryer sections and the area around the dryers is naturally well ventilated by ambient air. This helps to promote evaporation of water from the sheet and further increase drying rate.

Higher felt wrap angles, good thermal contact between the sheet and top dryers, and improved sheet ventilation all tend to increase the rate of heat transfer and correspondingly reduce the surface temperatures of the top dryer cylinders.

Although the felt wrap angle is equally high on bottom dryers as on top dryers, the dryer felt keeps the sheet from contacting the hot surfaces of the bottom dryers. As a result, the amount of heat that is trans-

ferred from bottom dryers to the sheet and the drying rate contribution from these bottom dryers are correspondingly quite low.

Because heat transfer from the top dryers to the sheet is high, the drop in temperature from the steam inside the top dryers to the outer surfaces of the top dryers will tend to be large. That is, the surface temperatures of top single-felt dryers will be much lower than the dryer steam temperature.

Conversely, because heat transfer from bottom dryers to the sheet is so low, the drop in temperature from the steam inside bottom dryers to the outer surfaces of bottom dryers will be much less. That is, the surface temperatures of bottom single-felt dryers will tend to be much closer to the dryer steam temperatures.

The above points can be seen in the following graph that shows dryer surface temperatures in a dryer section that has a single-felt configuration for the wet end dryers. As shown in this figure, dryer surface temperatures have a “saw tooth” pattern, with bottom dryers being hotter than top dryers. If the bottom dryers were not heated with steam, then the difference between top and bottom dryer surface temperatures would be much less.

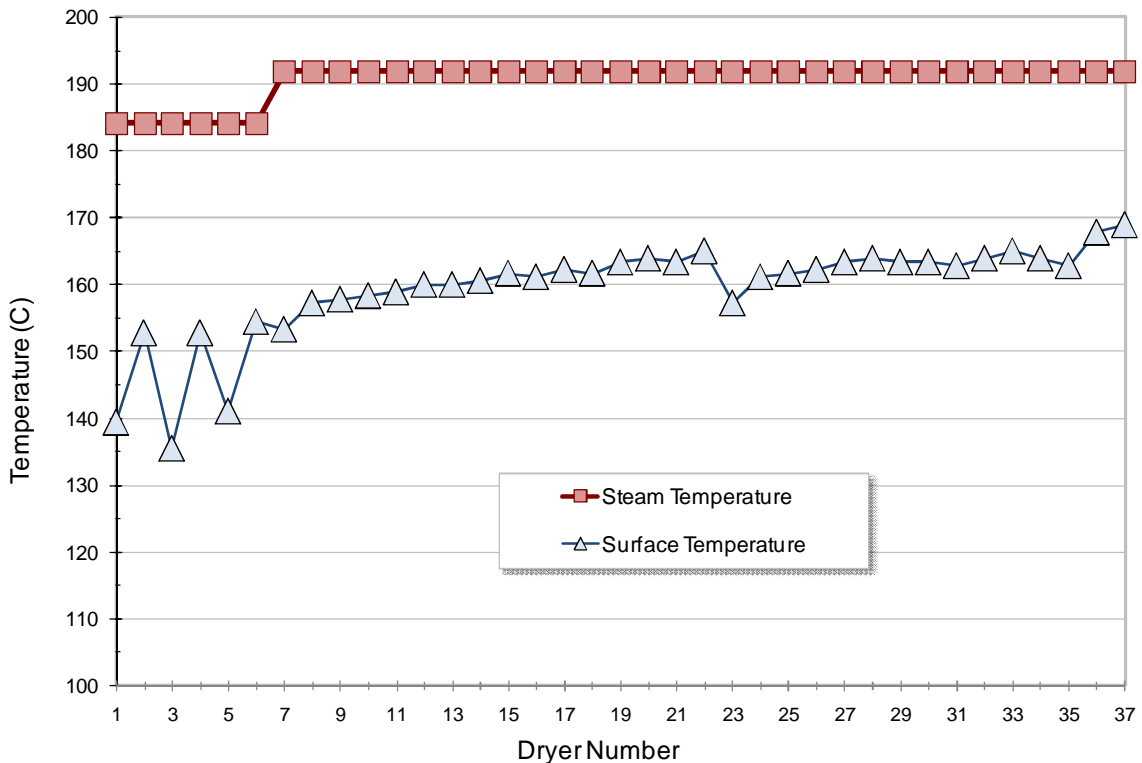

**42 lb linerboard, 505 mpm (1658 fpm)**

## DRYER CAPACITY

---

Since the sheet does not contact surfaces of bottom single-felt dryers, the drying capacity associated with bottom dryers will be low. Although single-felt dryer sections have higher felt wrap angles and improved ventilation, these factors are not enough to offset the loss in drying that results from the sheet not contacting the surfaces of the bottom dryers.

As a general rule, the combination of a top dryer and a bottom dryer in a single-felt dryer section will have about 60% of the drying capacity of a pair of dryers in a conventional two-tier, two-felt dryer configuration.

When the single-felt dryer section was first introduced, there were reports that single-felt dryer sections did not lose drying capacity. There are two likely reasons for these reports:

1. The machine speeds increased due to improved runnability and this was incorrectly reported to be the result of increased drying capacity.
2. The machines had excess drying capacity and the loss in drying from the single-felt dryers sections was compensated by increasing the steam pressures in the subsequent dryer sections.

The general consensus today is that top single-felt dryers contribute more drying and bottom single-felt dryers contribute much less (almost nothing) to drying paper. More specifically,

1. Heat transfer from top single-felt dryers to the sheet is increased by higher felt-wrap angles and by improved ventilation. The increase is typically 20% compared to a conventional two-felt dryer configuration.
2. Heat transfer to the sheet from bottom single-felt dryers is significantly reduced by the insulating effect of the dryer felt. The amount of heat transfer to the sheet from the bottom dryers of a single-felt dryer section is generally assumed to be near zero.

## CHECKING DRYER CAPACITY

---

If a two-felt dryer section is to be converted to a single-felt dryer section, the drying capacity of the top dryers will increase and the drying capacity of the bottom dryers will decrease. The impact of this conversion on overall drying capacity can be determined from a trial on a paper machine with a single-felt dryer section, as follows: Operate the machine with the bottom dryers steam-heated, then valved off, then

steamed again, all while running the same grade at the same speed. If the bottom single-felt dryers do have some positive contribution to drying, then steam pressures in the rest of the dryers should increase and then go back down to their original levels when the steam is turned back on. If, on the other hand, there is no change in the steam pressures in the rest of the dryers, then the results would indicate that the bottom single-felt dryers have no effect on drying capacity.

It does not make any difference how the capacity is distributed between the top and bottom dryers, just what the net contribution will be. It is common to use "effectiveness factors" of 1.20 for the top dryers and 0 for the bottom dryers. These are the factors that are used in the Drying Rate program that is available from Kadant Johnson or at [www.kadant.com](http://www.kadant.com).

In reality, effectiveness values might really be 1.15 and 0.05 rather than 1.20 and 0.00, but this would not make any difference to the overall drying capacity of the dryer section. Note that the TAPPI procedures for evaluating drying capacity (Technical Information Paper 0404-07) allow for only two effectiveness factors: 0 and 1. Any dryer that is steamed and contacts the sheet gets a factor of 1. Dryers that are not steamed or do not contact the sheet have a factor of 0. It is more accurate to assume the top dryers contribute more than a standard dryer.

## STEAM HEATING BOTTOM DRYERS

---

Even though there is limited heat transfer from bottom single-felt dryers, bottom dryers are still oftentimes heated with steam.

Even though there is limited heat transfer from bottom single-felt dryers, bottom dryers are still oftentimes heated with steam. Heating the bottom dryers will tend to keep the dryers clean and dry, resulting in less rust, and the dryers will be dimensionally more stable. Dryers on machines that operate intermittently are more susceptible to rusting.

The diametrical dimensional stability is important for those dryers that are driven through interconnecting gears. As noted earlier, interconnecting gears force each of the dryers to rotate at exactly the same *rotational* speed. The dryer felt, however, acts as a very large drive belt, attempting to keep the dryers rotating at the same *surface* speed. If the top and bottom single-felted dryers have different outside diameters, then the felt (drive belt) will put excessive stress on the dryer gears. This can greatly reduce the gear life and may even cause catastrophic gear failures.

One possible solution to this problem is to remove the interconnecting gears so that the bottom dryers are driven only by the dryer felt. This concept is called a "felt-driven" dryer section or a "silent dryer" drive system. If the bottom dryers are driven only by the dryer felt, then the bottom dryers will rotate at the same surface speed as the top dryers, regardless of their diameters. There is no stress on the interconnecting

---

If the bottom dryers cannot be disconnected from the drive train, then the next best solution is to disconnect the bottom dryers from the steam system.

---

gears because there are no interconnecting gears. And no need to steam-heat the dryers.

If the bottom dryers cannot be disconnected from the drive train, then the next best solution is to simply disconnect the bottom dryers from the steam system. If the steam pressure in the top dryers is low, generally below 0.35 bar (5 psig), then the temperature of unheated bottom dryers will normally stabilize at a value that is close to that of the steam-heated top dryers (approximately 65 C [150 F]).

If, however, the dryer gearing configuration does not allow the bottom dryers to be disconnected from the drive train and the top dryers are operated at high steam pressures (for example, on a linerboard machine), then the bottom dryers should be steam-heated so that their operating surface temperatures are similar to those of the top dryers and their dryer diameters are correspondingly close to the diameters of the top dryers when the dryer section is in operation.

To achieve equal dryer surface temperatures, the bottom dryer steam pressures must be set somewhat less than the steam pressures in the top dryers. This is because the top dryers are being cooled by direct contact with the sheet while the bottom dryers are not. The steam pressure in bottom dryers of a single-felt dryer section should be approximately 0.70 bar (10 psi) less than the steam pressure in top dryers to have similar surface temperatures.

Although bottom dryers should be run at a lower pressure than the top dryers, there is no fixed pressure difference for steam heating bottom dryers. Typically, the bottom single-felt dryers will have 11 to 16 C (20 to 30 F) higher surface temperatures than the top dryers, if both are operated at the same pressure. However, operating the bottom dryers about 0.70 bar (10 psi) lower than the top dryer pressures is a reasonable starting point, when the top dryer pressures are low. If the top dryers were operated at 0.70 bar (10 psig) and the bottom dryers were operated at 0 bar (psig), then the difference in saturation temperature would be 15 C (27 F). This puts it in the right range.

## STEAM CONDENSING LOAD

---

Even though there is little contribution from bottom single-felt dryers to paper drying (i.e., water evaporation), some heat will still be transferred from the steam, if the dryer is steam-heated. This heat is transferred to the dryer felt as it passes over the outer surface of the dryers and also to the surrounding air from the unwrapped areas of the dryer.

Most of the heat that is transferred from bottom dryers will go into the felt or into surrounding air. Some of the heat that goes into the felt may then be conducted to the sheet, but this is likely to be a very small amount. The majority of this energy will ultimately end up in exhaust

air. The amount of steam that is condensed by the bottom dryers is typically 5 to 10 kg/hr-m<sup>2</sup> (1 to 2 lb/hr-ft<sup>2</sup> (depending on speed and steam pressure), plus about 23 kg/hr (50 lb/hr) for each dryer head for radiant and convective losses.

On a 1.8 m (6 ft) diameter, 7.6 m (300 in) face dryer, this would be a condensing load of about 225 to 450 kg/hr (500 to 1000 lb/hr). This energy is wasted, unless this steam heat contributes to drying or reduces the amount of steam required to heat the ventilation air. Neither is very likely. That is, the overall energy efficiency is reduced by steam heating bottom single-felt dryers.

## BLOW-THROUGH STEAM

---

**Bottom dryer syphons must be properly sized and the steam system properly designed to reflect the low steam condensing loads of the bottom dryers.**

---

Steam in the bottom dryers will condense as it transfers its heat to the dryer shell and this condensate must be removed from the dryer with a syphon. These syphons remove not only the condensate, but also uncondensed steam (i.e., blow-through steam). Bottom dryer syphons must be properly sized and the steam system properly designed to reflect the low steam condensing loads of the bottom dryers.

The amount of blow-through steam depends on a number of factors: Size of the syphon, operating differential steam pressure, machine speed, steam pressure, and condensing load. If bottom dryers are equipped with the same size syphons and operate at the same steam pressures as top dryers, the resulting blow-through steam from the bottom dryers will be much higher than necessary to evacuate the condensate. This blow-through steam is then likely to be wasted by sending it to a vacuum condenser or venting to the atmosphere. In either case, this is a waste of steam energy.

If the blow-through steam is to be cascaded, it is best to cascade from top dryers to bottom dryers, rather than the other way around. If blow-through steam from bottom dryers is cascaded to the top dryers, then the bottom dryers will definitely be higher in surface temperature than the top dryers, which is the wrong way to operate a single-felt dryer section that has inter-connecting gears.

## STEAM SYSTEM DESIGN

---

The simplest steam system for heating bottom dryers would be a separate steam pressure control group, with the bottom dryers operated at some steam pressure below that of the top dryers.

Steam from top single-felt dryers could be cascaded to bottom single-felt dryers, to ensure that bottom dryers will always be operating at a lower pressure than the top dryers, but this reduces the control flexibil-

ity for the top dryers. Further, this can only be done if the top dryers have stationary syphons. Stationary syphons require less pressure differential to drain the dryers and much less blow-through steam than rotary syphons. This helps improve the control range and prevent venting which would otherwise occur because the bottom dryers do not condense much steam.

In order to have maximum flexibility in selecting the top dryer steam pressures, in particular for printing and writing grades, top dryers are *not* cascaded to bottom dryers. What's more, it is often necessary to operate top dryers at sub-atmospheric pressures to avoid picking. This makes it very difficult to cascade the blow-through steam to the bottom dryers. Also, top dryers are typically individually controlled which makes it even more difficult to cascade.

A cascade system could be used on a board machine, however, where top dryer pressures are high and top dryers would be grouped together rather than individually controlled.

Most often, both the top and bottom single-felt dryers will discharge directly to a condenser. The top dryers will have individual control for flexibility and the bottom dryers will be grouped into one section with a differential pressure control valve. A typical schematic for this system is shown in the figure below.

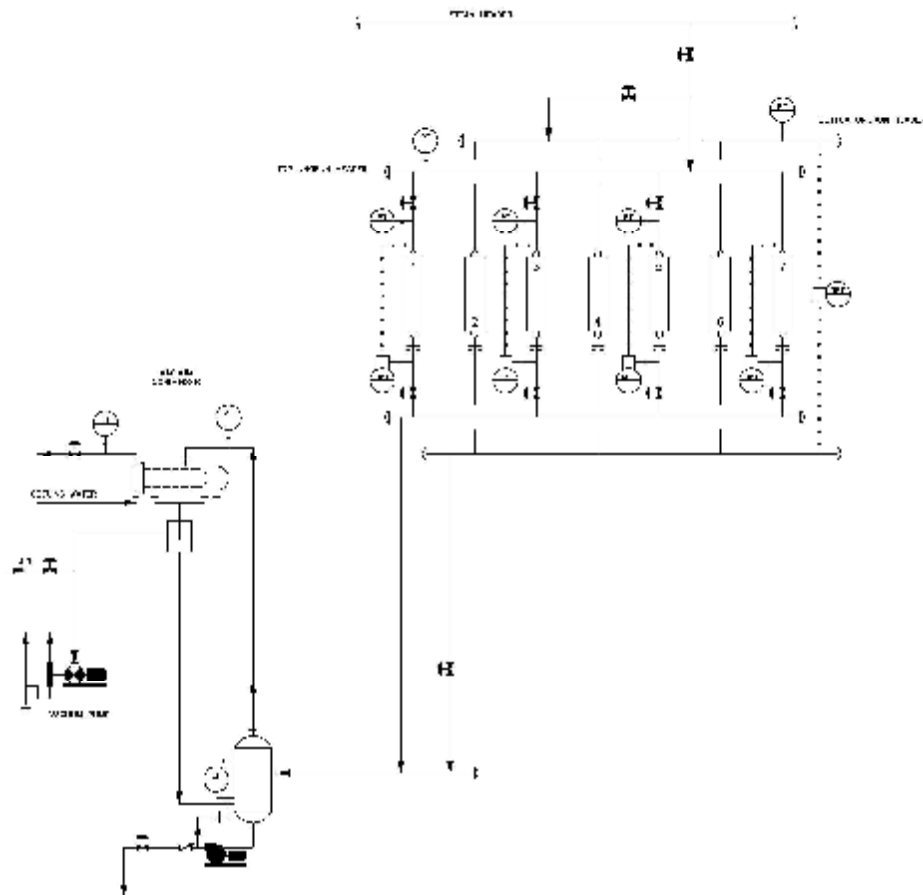

It is critical that the blow-through steam from the bottom dryers be restricted. The bottom dryers should have stationary syphons to minimize the differential pressure requirements and orifice plates to restrict the flow of blow-through steam. If rotary syphons are used, the syphon size should be small to minimize blow-through steam.

Dealing with bottom single-felt dryers is one of the more difficult challenges in designing a dryer drainage system. The condensate from the bottom dryers can be recovered with a separator tank, if one is available. If a tank is not available, the energy savings from these low flow rates is generally insufficient to justify the cost of a new separator station. If the bottom dryer syphons are properly sized to reflect the low pressures and low condensing loads, then the amount of blow-through steam that leaves the bottom dryers will be fairly low. Condensate and blow-through steam from these bottom dryers can then be discharged to a condenser or be used for process heating (hot water, showers, PV coils, etc).

## CONCLUSIONS

---

Following is a summary of recommendations for bottom dryers of single-felt dryer sections:

1. If possible, the bottom dryers should be taken out of the dryer gear train.
2. If the bottom dryers are not driven by gears, they do not have to be heated.
3. If the bottom dryers remain in the gear train, then the bottom dryers should be disconnected from the steam system, unless the operating pressures in the top dryers are greater than 0.35 bar (5 psig).
4. If the bottom dryers remain in the gear train and the operating pressures in the top dryers are greater than 0.35 bar (5 psig), then the bottom dryers should be heated, to stabilize their diameters.
5. If the bottom dryers are heated, the dryers should be placed in a separate steam control group and the steam pressures should be about 0.70 bar (10 psi) lower than the top dryers.
6. The syphons in the bottom dryers should be sized to match the low pressures and low condensing loads of the bottom dryers, in order to minimize the amount of blow-through steam that must be handled by the steam system.
7. The condensate and blow-through steam from bottom dryers should either go to a vacuum condenser or be used for process heating.

Kadant Johnson is a global leader in the design, manufacture, and service of dryer drainage systems, rotary joints, syphon systems, and related equipment for the dryer section of the paper machine. For more information about Kadant Johnson products and services, email [info@kadant.com](mailto:info@kadant.com) or visit [www.kadant.com](http://www.kadant.com).

- *Steam and Condensate Systems*
- *Dryer Section Surveys*
- *Dryer Management System® control software*
- *Stationary Syphons*
- *Rotating Syphons*
- *Rotary Joints*
- *Turbulator® Bars*
- *Thermocompressors*
- *Desuperheaters*
- *Direct Injection Water Heaters*
- *Vortec™ Vacuum Generators*
- *Sight Flow Indicators*
- *Flexible Metal Hoses*
- *Installations Services*

**KĀDANT**  
AN ACCENT ON INNOVATION